



Challenges in production of ultra clean fuel

February 19, 2009

Yasuhiro Araki

Japan Energy Corporation

7th ASIAN PETROLEUM
TECHNOLOGY SYMPOSIUM

Topics

1. Outline of JEC (Japan Energy Co.)
2. Background
 - 2.1. Importance of reducing sulfur content in gasoline
 - 2.2. S free ($S < 10\text{ppm}$) gasoline production in JEC
3. Challenges in production of ultra clean ($S < 1\text{ppm}$) gasoline
 - 3.1. $S < 1\text{ppm}$ gasoline production by sorptive desulfurization
 - 3.2. The application of sorptive desulfurization for S free gasoline production to reduce octane number loss
4. Summary



Topics

1. Outline of JEC (Japan Energy Co.)

2. Background

2.1. Importance of reducing sulfur content in gasoline

2.2. S free ($S < 10\text{ppm}$) gasoline production in JEC

3. Challenges in production of ultra clean ($S < 1\text{ppm}$) gasoline

3.1. $S < 1\text{ppm}$ gasoline production by sorptive desulfurization

3.2. The application of sorptive desulfurization for S free gasoline production to reduce octane number loss

4. Summary



Outline of JEC

History of Nippon Mining Holdings Group

- 1905 Fusanosuke Kuhara opened Hitachi Mine (Copper Mine)**
- 1928 Incorporating other companies, Kuhara Mining Co. established Nippon Sangyo Co. (NISSAN)**
- 1929 Nippon Mining Co. was established, and succeeded metal mining business of NISSAN**
- 1961 Nippon Mining Co. started operating Mizushima Refinery**
- 1993 Nippon Mining Co. changed its name to Japan Energy Co.**
- 2002 Japan Energy and Nippon Mining & Metals jointly established Nippon Mining Holdings, Inc.**



Operating Units

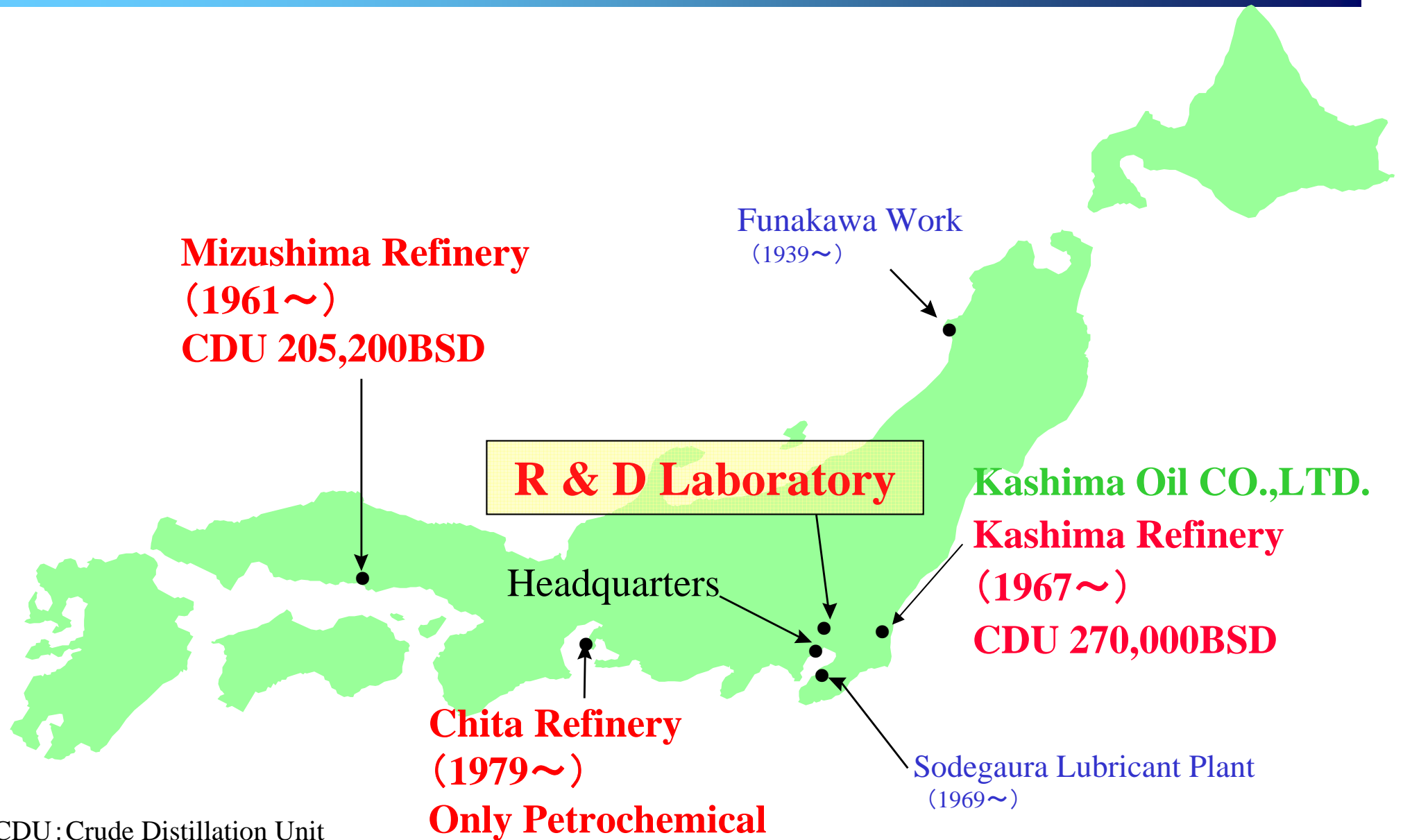

※CDU: Crude Distillation Unit



Topics

1. Outline of JEC (Japan Energy Co.)

2. Background

2.1. Importance of reducing sulfur content in gasoline

2.2. S free ($S < 10\text{ppm}$) gasoline production in JEC

3. Challenges in production of ultra clean ($S < 1\text{ppm}$) gasoline

3.1. $S < 1\text{ppm}$ gasoline production by sorptive desulfurization

3.2. The application of sorptive desulfurization for S free gasoline production to reduce octane number loss

4. Summary



Importance of reducing sulfur content in gasoline

- To maintain the performance of emission reducing catalyst which is affected by sulfur
(Fuel is consumed to regenerate the sulfur-poisoned catalyst.)
- To reduce Sulfur Oxides (SO_x) emission by gasoline consumers

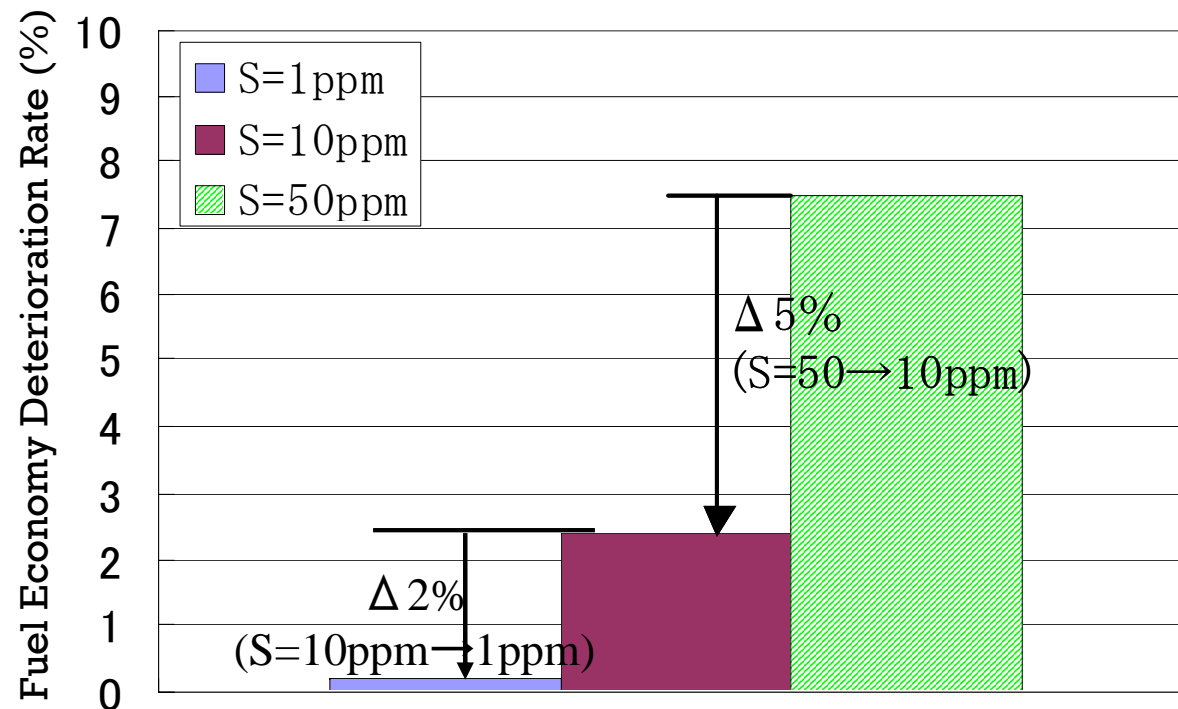
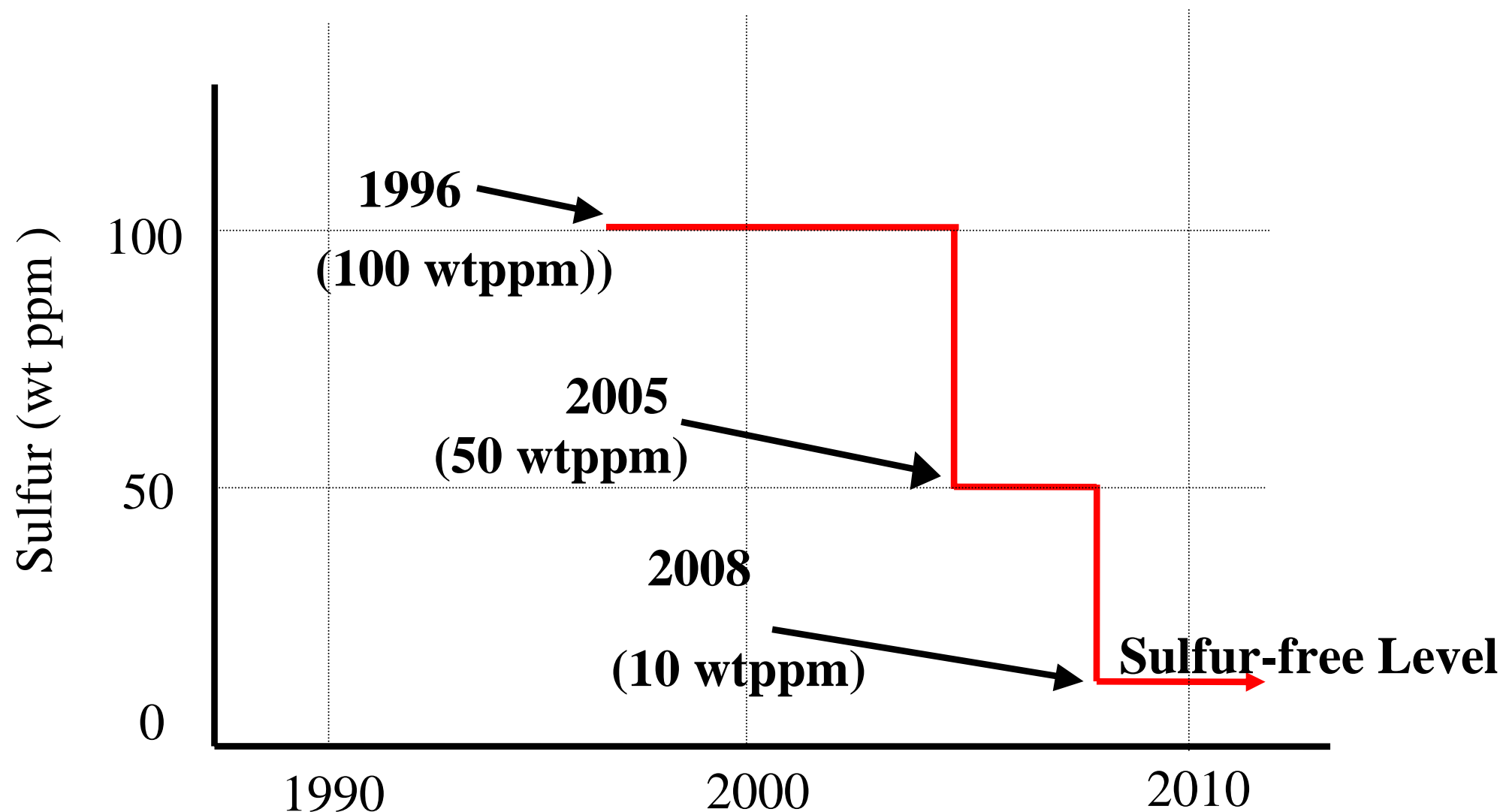

Fig. Effects of sulfur on fuel economy
 T. Kaneko et al., JSAE paper No.131-05, p.5 (2005)



History of Regular Gasoline Sulfur Specifications in Japan



Topics

1. Outline of JEC (Japan Energy Co.)

2. Background

2.1. Importance of reducing sulfur content in gasoline

2.2. S free ($S < 10\text{ppm}$) gasoline production in JEC

3. Challenges in production of ultra clean ($S < 1\text{ppm}$) gasoline

3.1. $S < 1\text{ppm}$ gasoline production by sorptive desulfurization

3.2. The application of sorptive desulfurization for S free gasoline production to reduce octane number loss

4. Summary



Typical Composition of Regular Gasoline

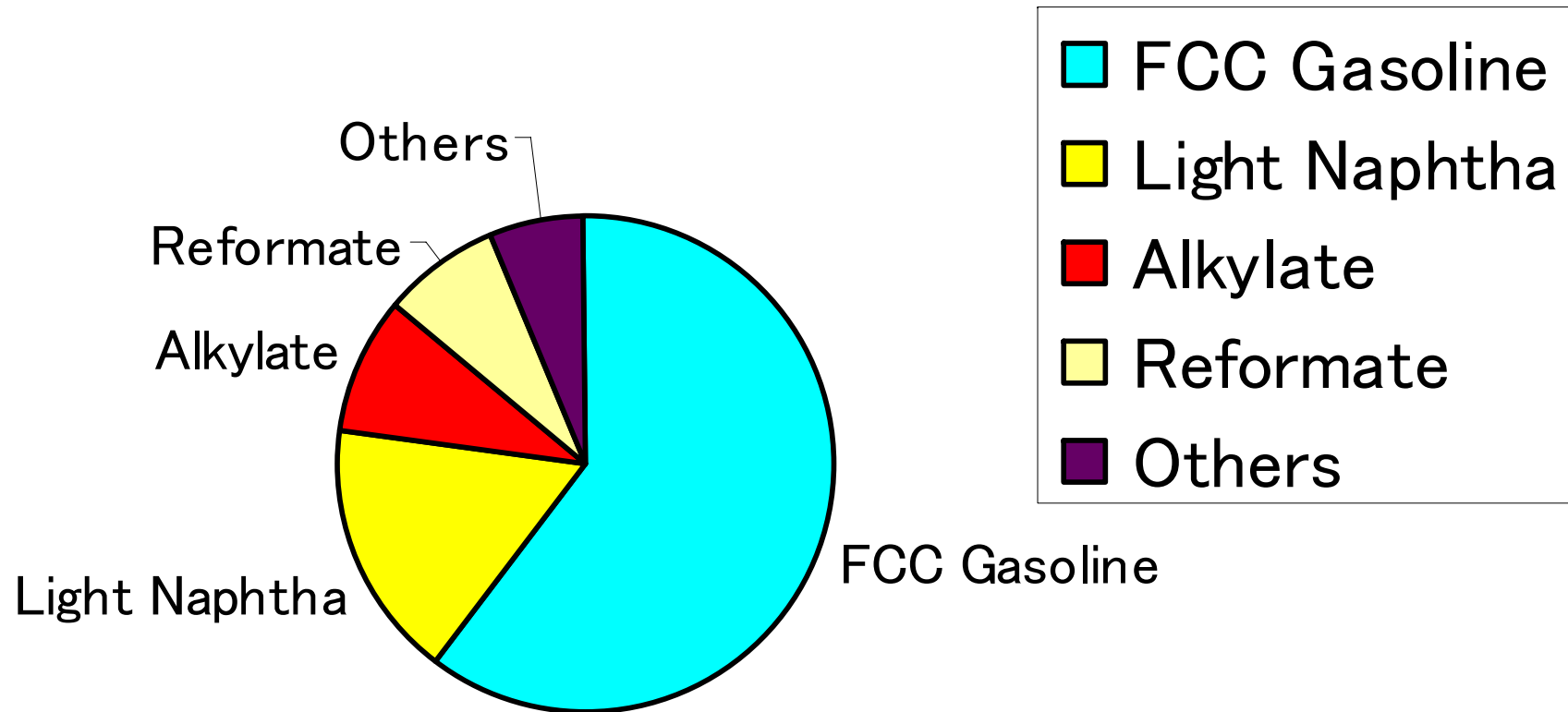

Only FCC gasoline contains sulfur over 10ppm.

→ The most effective way to meet sulfur specifications in regular gasoline is to reduce the sulfur content in FCC gasoline.



S free gasoline production in JEC

- Mizushima refinery
 - Installation of FCC gasoline HDS unit in 2005
- Kashima refinery
 - Installation of FCC gasoline HDS unit in 2004

※HDS: Hydrodesulfurization



Sulfur-free gasoline production in Mizushima refinery

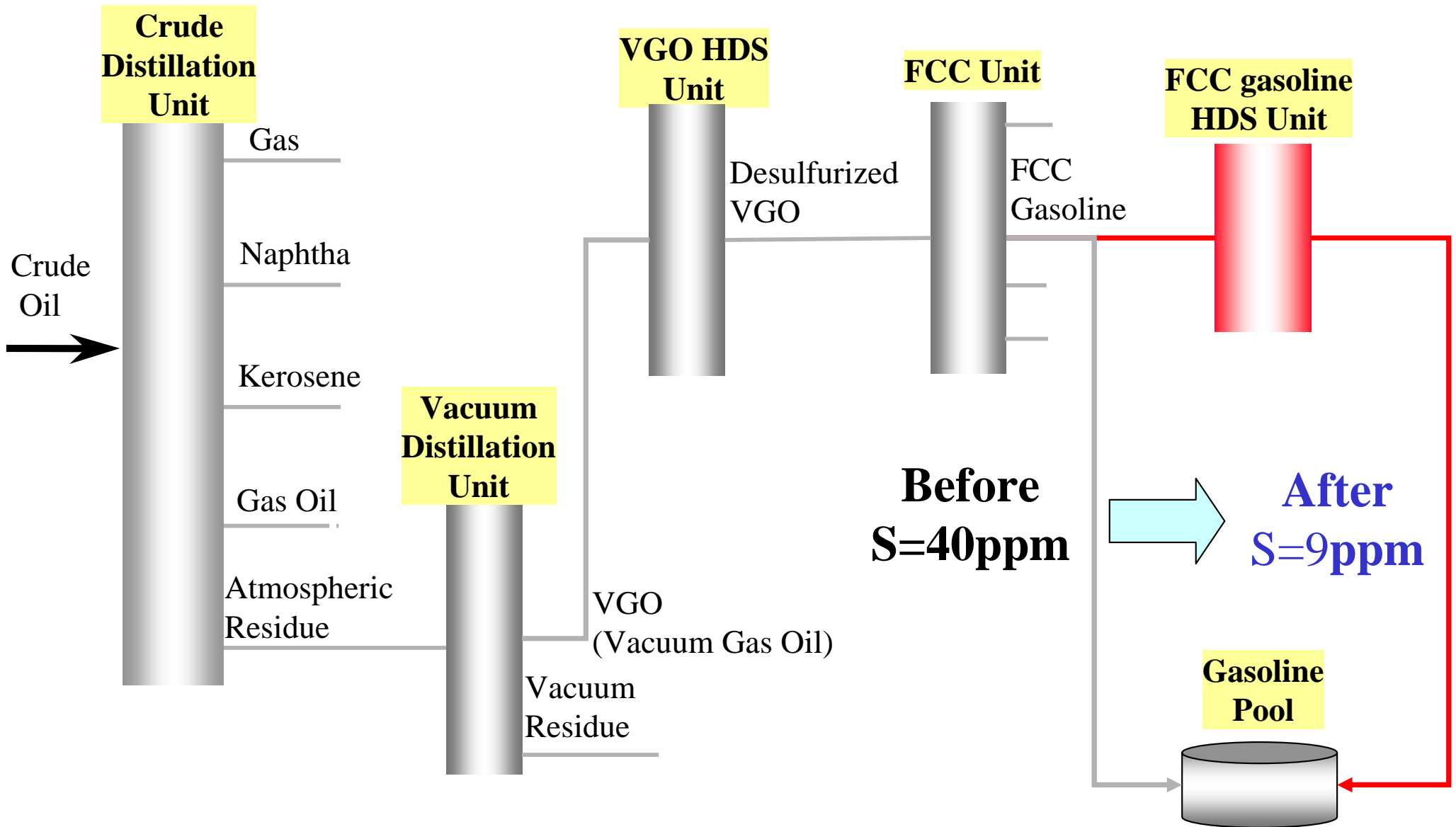

Topics

1. Outline of JEC (Japan Energy Co.)

2. Background

2.1. Importance of reducing sulfur content in gasoline

2.2. S free ($S < 10\text{ppm}$) gasoline production in JEC

3. Challenges in production of ultra clean ($S < 1\text{ppm}$) gasoline

3.1. $S < 1\text{ppm}$ gasoline production by sorptive desulfurization

3.2. The application of sorptive desulfurization for S free gasoline production to reduce octane number loss

4. Summary



Limitation of HDS on production of S<1ppm gasoline

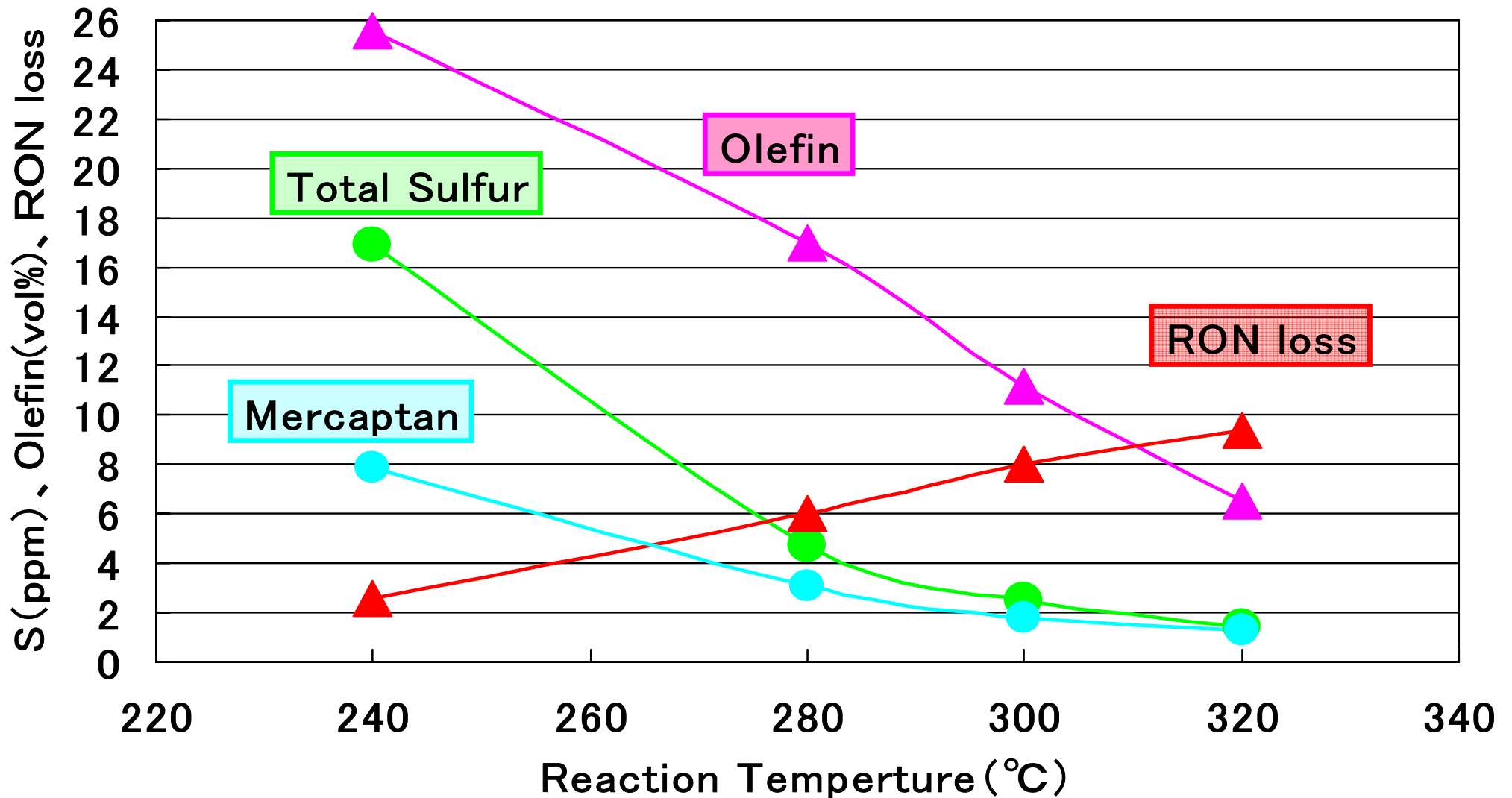

Feed: Whole FCC gasoline (S=76ppm, olefin=30vol%)

Catalyst: HOP461 (CoMo type) Reaction condition: 1.0MPa, LHSV=4(h⁻¹), H₂/Oil=300 (L/L)

※RON: Research octane number



Reactions in FCC gasoline HDS

#Desired reaction

- Desulfurization of organosulfur

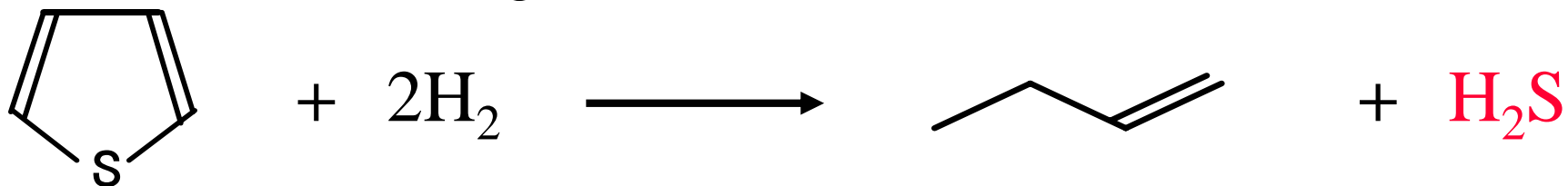

#Undesired reactions

- Hydrogenation of olefin \rightarrow octane number loss

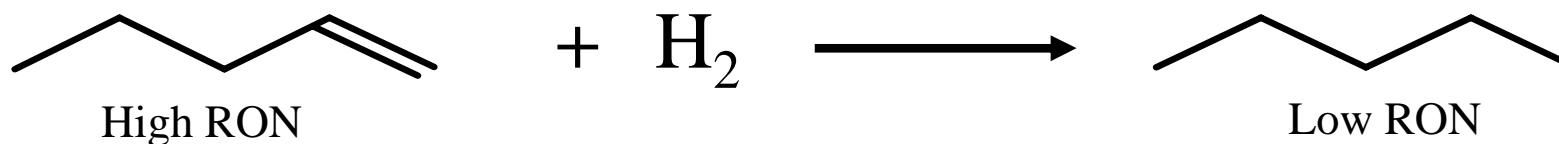

- Recombination of olefin and $\text{H}_2\text{S} \rightarrow$ reproduction of organosulfur

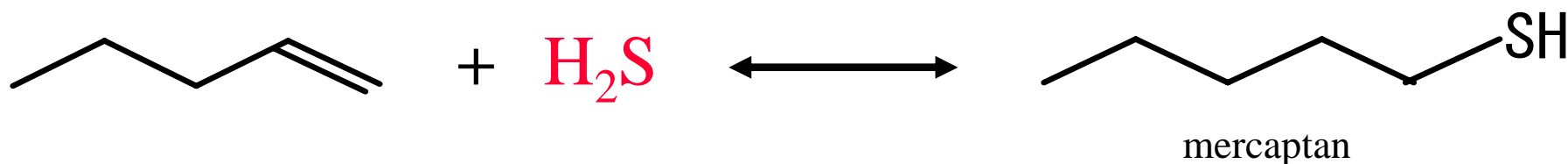

How can FCC gasoline be desulfurized without olefin saturation?

- We clarified that sorption is effective for FCC gasoline desulfurization up to $S < 1$ ppm without olefin saturation.

	Good Properties	Advantages
1	No H ₂ S generation (leading no recombined mercaptan)	Capable of desulfurization by 1 ppm-S below
2	Little hydrogen consumption (leading negligible olefin saturation)	No octane number loss
3	High S pick-up capacity relative to adsorption	Capable of long life operation



Reactions in FCC gasoline sorptive desulfurization

#Desired reaction

- Desulfurization of organosulfur

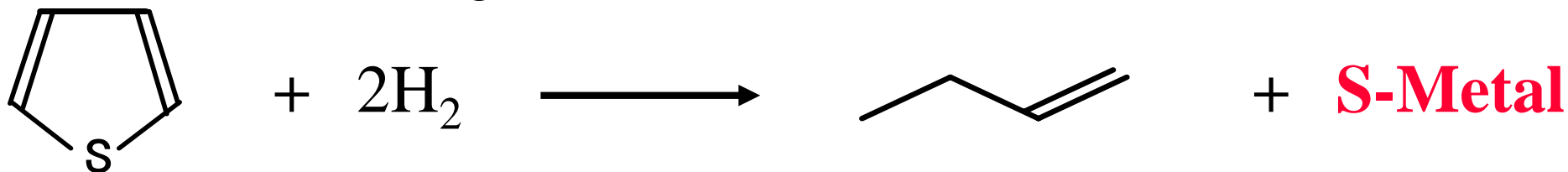

~~#Undesired reactions~~

- ~~Hydrogenation of olefin \rightarrow octane number loss~~

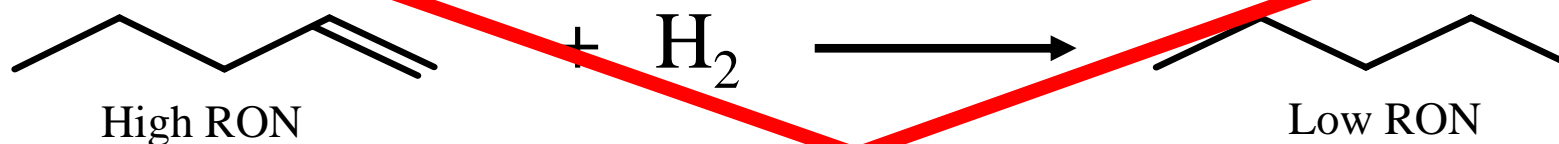

- ~~Recombination of olefin and H_2S \rightarrow reproduction of organosulfur~~

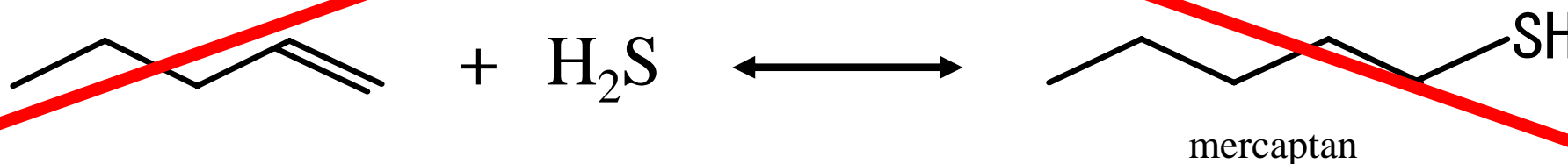

Sorptive desulfurization mechanism

Proposed reaction mechanism (at 325°C)

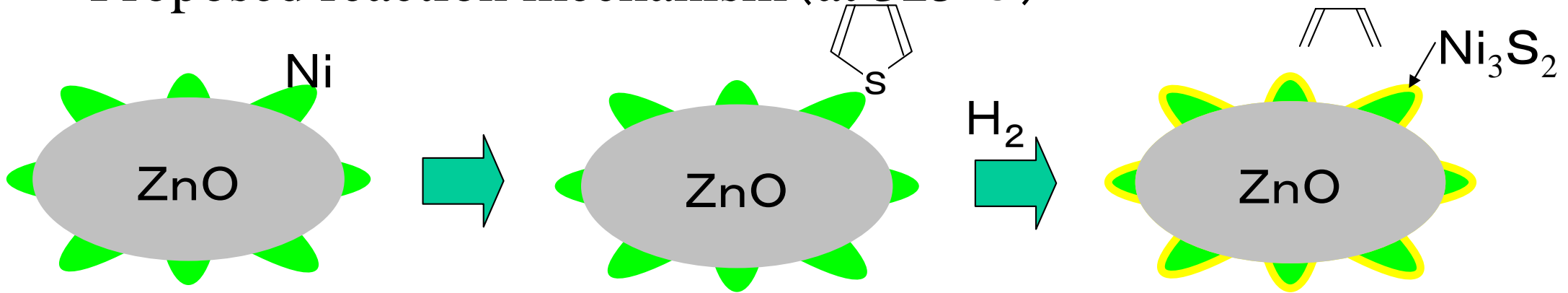

Sorption refers to a reaction in which both adsorption and absorption are taking place simultaneously

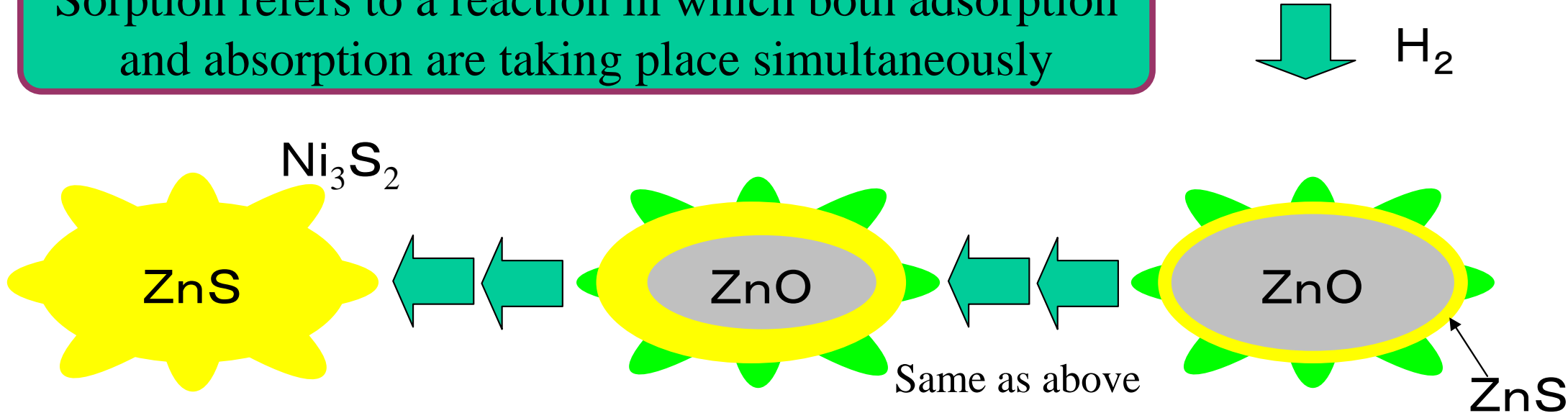

I.V.Babich et al. Fuel, 82, 607, 2003



Sorptive desulfurization of FCC gasoline model compounds

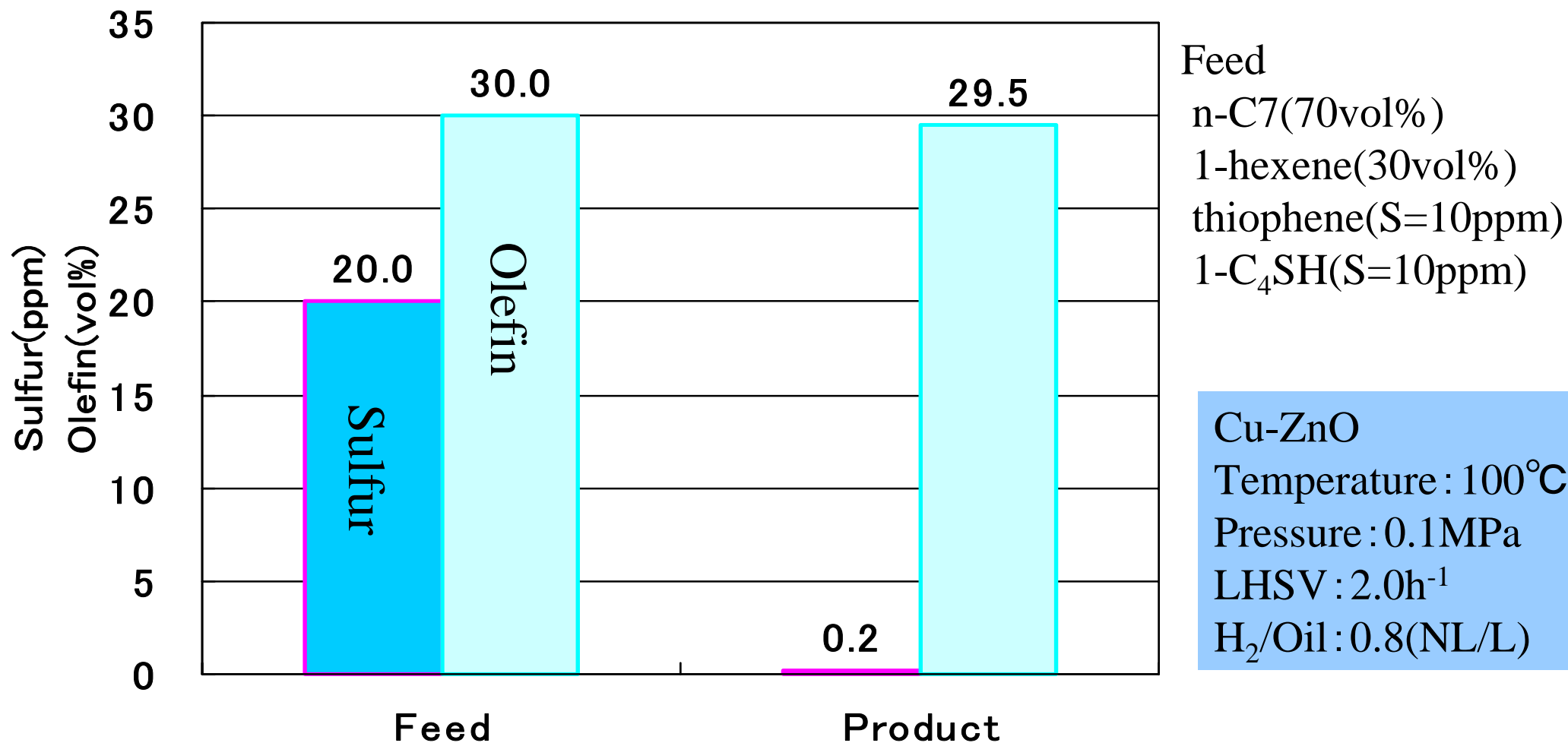

FCC gasoline model feed is desulfurized up to S<1ppm without olefin saturation



Life span test of FCC heavy gasoline desulfurization by sorption

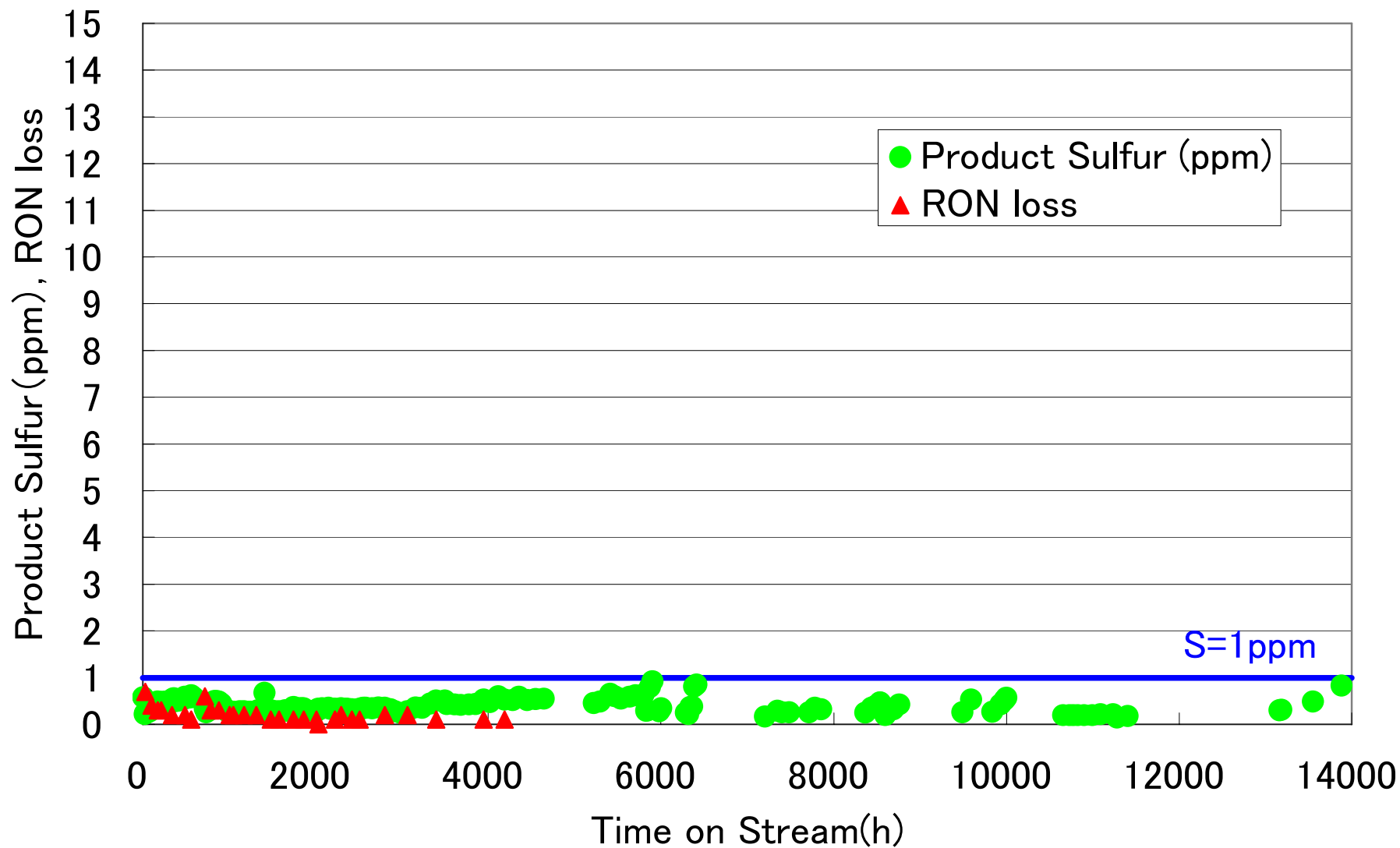

Feed: FCC heavy gasoline (S=15ppm, olefin=11vol%)

Sorbent: Ni-ZnO, Reaction condition: 300°C, 0.5MPa, LHSV=2.1(h⁻¹), H₂/Oil=20 (L/L)



Topics

1. Outline of JEC (Japan Energy Co.)
2. Background
 - 2.1. Importance of reducing sulfur content in gasoline
 - 2.2. S free ($S < 10\text{ppm}$) gasoline production in JEC
3. Challenges in production of ultra clean ($S < 1\text{ppm}$) gasoline
 - 3.1. $S < 1\text{ppm}$ gasoline production by sorptive desulfurization
 - 3.2. The application of sorptive desulfurization for S free gasoline production to reduce octane number loss**
4. Summary



Lower HDS severity reduces RON loss

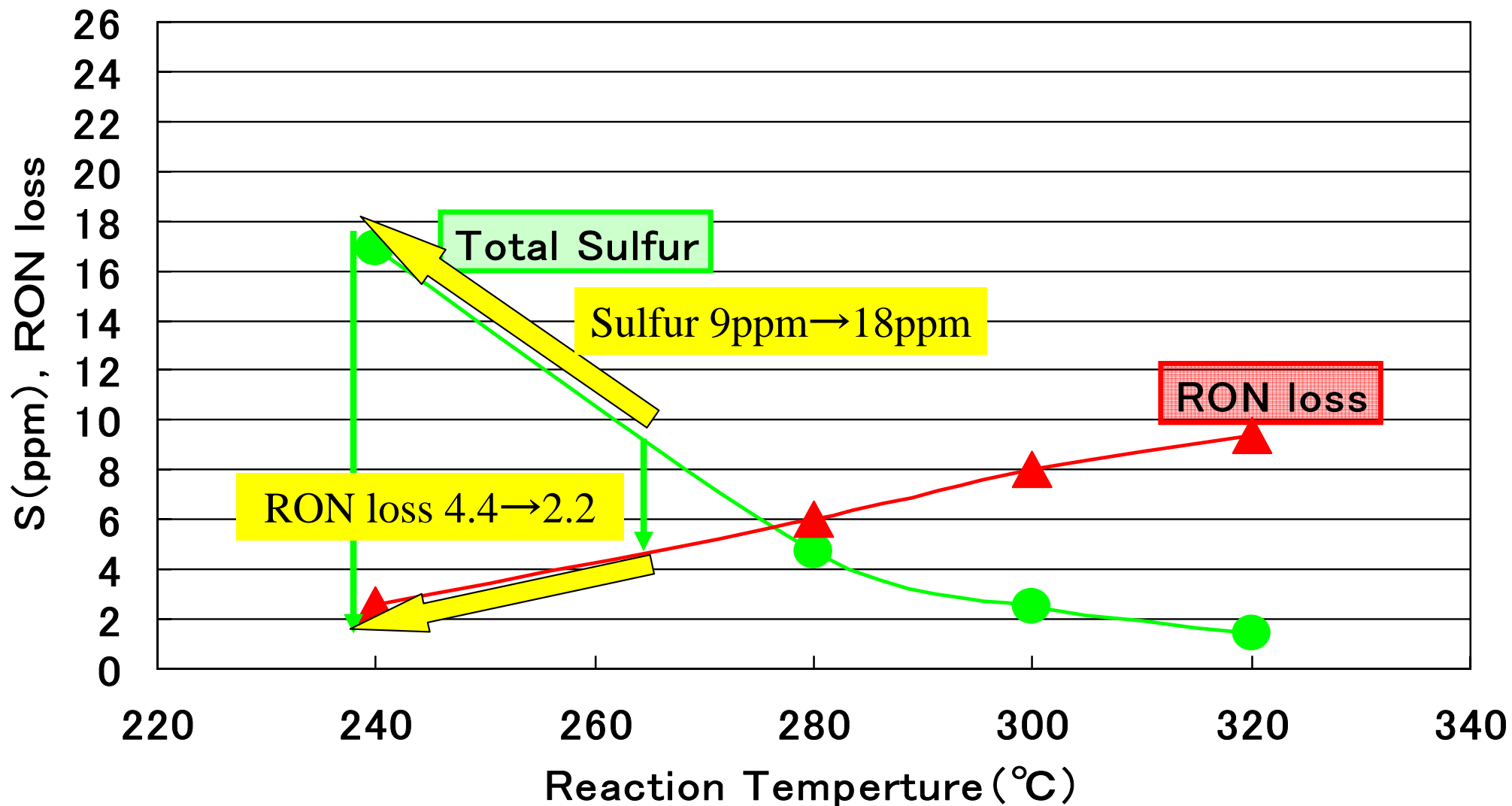

Feed: Whole FCC gasoline (S=76ppm, olefin=30vol%)

Catalyst: HOP461 (CoMo type) Reaction condition: 1.0MPa, LHSV=4(h⁻¹), H₂/Oil=300 (L/L)



The Application of Sorption for FCC gasoline HDS

★ HDS only

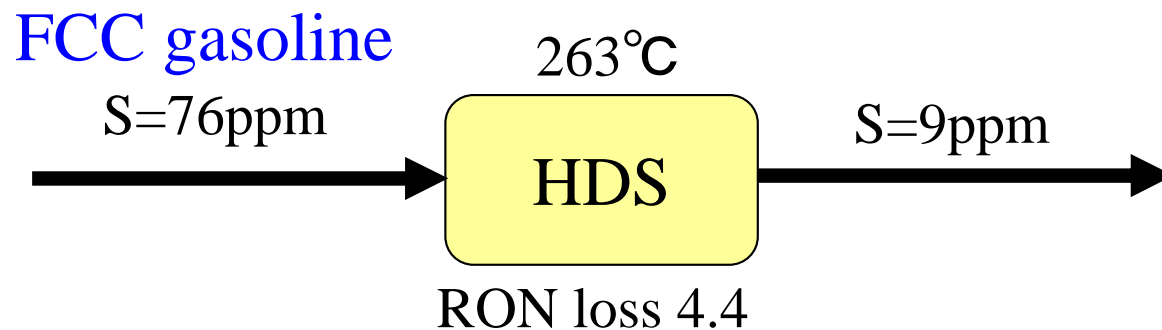

Overall
RON loss

4.4

★ Mild HDS + Sorptive Desulfurization

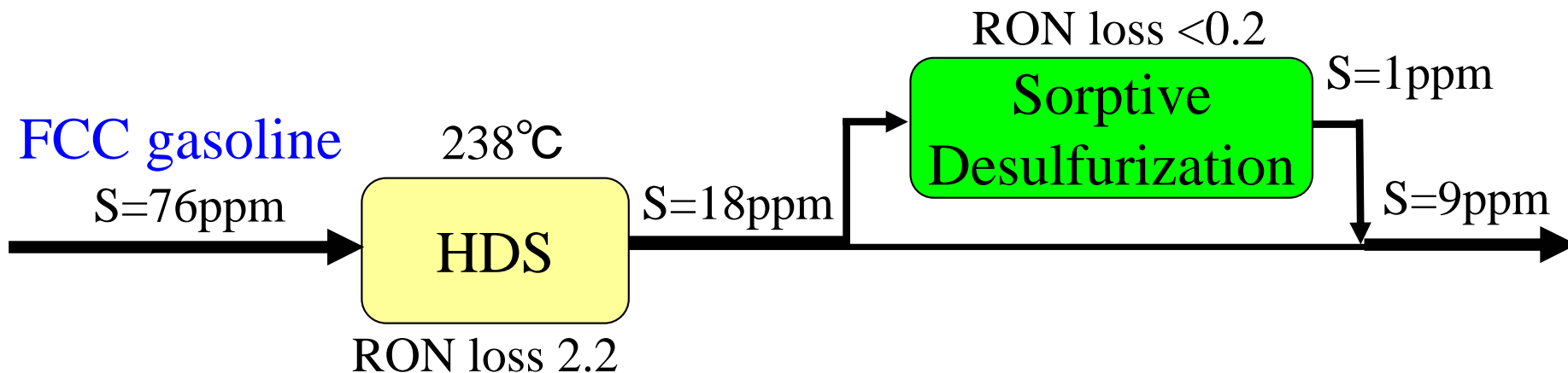

2.3



Topics

1. Outline of JEC (Japan Energy Co.)
2. Background
 - 2.1. Importance of reducing sulfur content in gasoline
 - 2.2. S free ($S < 10\text{ppm}$) gasoline production in JEC
3. Challenges in production of ultra clean ($S < 1\text{ppm}$) gasoline
 - 3.1. $S < 1\text{ppm}$ gasoline production by sorptive desulfurization
 - 3.2. The application of sorptive desulfurization for S free gasoline production to reduce octane number loss
- 4. Summary**



Summary

1. S free ($S < 10$ ppm) gasoline production in JEC

★ JEC installed FCC HDS processes in Mizushima and Kashima refinery.

2. Challenges in $S < 1$ ppm gasoline production method

★ We have developed **$S < 1$ ppm gasoline** production without RON loss **by sorptive desulfurization**.

3. The application of sorptive desulfurization to sulfur free ($S < 10$ ppm) gasoline production

★ **RON loss** in FCC HDS process can be **reduced by half**.



Thank you for your attention

